



Culligan®

Culligan® Commercial Reverse Osmosis Water Systems

assisted living facilities

cafeterias

casinos

educational facilities

food service

grocery

hotel/hospitality

institutions

laundry

corporate campuses

theme parks

vehicle wash

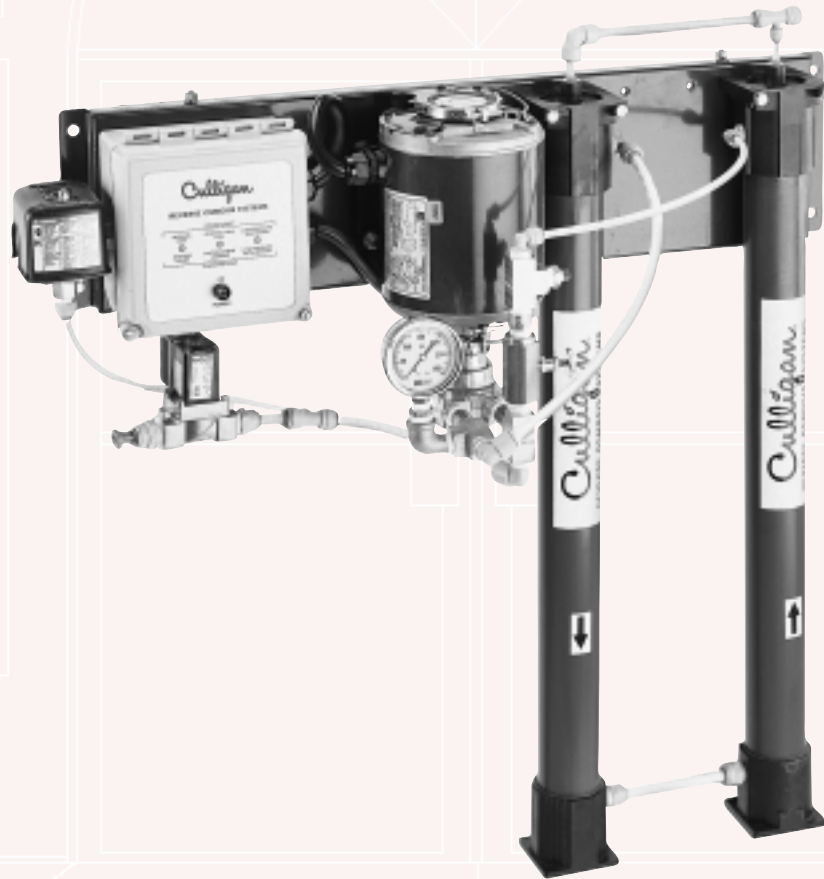

The Culligan® Series B Reverse Osmosis System

The Economical Water Treatment Solution.

Series B Standard Features

- Thin Film Composite RO Membranes—Rejects significant amounts of dissolved minerals, as well as colloids, particles organics and silica.*
- PVC/Noryl Module Housing—Corrosion resistant for long life.
- Positive Displacement Pump & Motor System—Optimum energy efficiency and quiet operation.
- Concentrate Recirculation—Saves water.
- Expandable Design—Grows with your business.
- Cartridge Filtration—Includes a replaceable 5-micron element that removes suspended particles to extend component life. *(not shown)*
- Pressure Indicator—Displays system operating pressure.

* Do not use with water that is microbiologically unsafe or of unknown quality without adequate disinfection before or after system.

The Culligan® Series B

Applications and Benefits

- Food & Beverage—Superior taste and increased cost savings.
- Ice Production/Drinking Water—Reduces scaling; improves taste and clarity.
- Restaurants—Improves steamer operation.
- Humidification—Reduces scaling and dusting.
- Grocery Stores—Prevents scaling in vegetable misters.
- Pretreatment—For use in deionization systems.
- Boilers—Improves energy efficiency.
- Vehicle Wash—Provides spot-free rinses.

Series B Plus Standard Features

- Low Pressure Switch—Protects the pump during low feed water pressure conditions.
- Low Pressure Auto Restart—Prevents permanent system shut down from low pressure conditions.
- Connection for Pretreatment Signal Switch and Level Control—Allows for easy integration and system operation.
- Auto Flush—Improves membrane life.
- System Indicator Lights—Visually displays system operation or alarm conditions.

Options

- Product Flow Meter—Displays system performance.
- Pressurized Product Storage Kit—Meets application specifications for bladder storage tanks.
- Wall Mounting Bracket—For easy installation.
- Sturdy Frame Mount Stand—Eliminates the need for mounting brackets.

System Specifications

Inlet Pressure (dynamic):	20–75 psig 138–515 kPa
Power:	115V/60 Hz/1P
Temperature:	33–100°F
Turbidity, max.:	1 NTU
pH Range:	6–11
Chlorine, max.:	0 mg/L
Total Dissolved Solids, max.:	2500 mg/L
Silt Density Index, max.:	3
Langlier Saturation Index, max.:	0
Iron, max.:	0.1 mg/L
Series B Plus Control Panel:	UL Listed

Model Descriptions

Model	Nominal Capacity** (GPD)	Approx. Recovery (%)	Motor HP	Approx. Operating Weight (lb)	
B-1L	250	25	1/3	45	
B-1L Plus					
B-2L	500	50		1/3	50
B-2L Plus					
B-3L	750		50	1/3	55
B-3L Plus					
B-4L	1000	50		1/2	60
B-4L Plus					

** Approximate initial capacity based on properly pretreated feed water of 600 ppm TDS as NaCl, 77°F, Silt Density Index below 3, and 225 psi applied pressure supplying water to atmosphere. Productivity will vary depending on the feed water conditions.

Underwriters
Lab

Hey Culligan Man!®
Culligan

Culligan Commercial @ Work™

www.culligan.com ^a

1-800-CULLIGAN
©2000 Culligan International Co.
SL-0004 DCO 992708
Printed in USA (09/00)
MOORE PART NO. 46907

SM ISO 9001
Certification

Culligan. Hey Culligan Man, Culligan Man, Culligan Commercial @ Work, www.culligan.com and Culligan Service Network are trademarks of Culligan International Company.

SERIES B AND B PLUS

REVERSE OSMOSIS SYSTEMS

SPECIFICATIONS AND OPERATING DATA

MODEL NUMBER		B-1S and B-1S Plus	B-1L and B-1L Plus	B-2L and B-2L Plus	B-3L and B-3L Plus	B-4L and B-4L Plus
Nominal Capacity*	gpd	125	250	500	750	1,000
	L/day	473	946	1,893	2,839	3,785
Element	Qty.	1-2" x 13"	1-2" x 26"	2-2" x 26"	3-2" x 26"	4-2" x 26"
Approx. Recovery %		25	25	50	50	50
Dimensions:						
Width	in	31	31	31	31	31
	m	0.79	0.79	0.79	0.79	0.79
Depth	in	12	12	12	12	12
	m	0.30	0.30	0.30	0.30	0.30
Height	in	19	32	32	32	32
	m	0.48	0.81	0.81	0.81	0.81
Pipe Size						
Feed (tube)	in	3/8	3/8	3/8	3/8	3/8
Product (tube)	in	3/8	3/8	3/8	3/8	3/8
Concentrate (tube)	in	1/8	1/8	1/8	1/8	3/16
Motor	HP	1/3	1/3	1/3	1/3	1/2
	KW	0.25	0.25	0.25	0.25	0.37
Approximate Operating Weight	lb	40	45	50	55	62
	kg	18.1	20.4	22.7	24.9	28.1

* Approximate initial capacity based on properly pretreated feedwater at 600 mg/L TDS as NaCl, 77°F (25°C) temperature silt density index below 3.0 and 225 psi (1550 kPa) applied pressure. Productivity will vary depending on other feed water conditions.

Culligan

Commercial Systems
 ©2000 Culligan
 1-800-CULLIGAN
 www.culligan.com
 Printed in USA Rev. 4/00
 DCO 992587
 SL-0078
 Moore Part No. 46948





LIMITED WARRANTY

COMMERCIAL/INDUSTRIAL REVERSE OSMOSIS SYSTEMS

You have just purchased one of the finest reverse osmosis water conditioning units made. As an expression of our confidence in Culligan products, your reverse osmosis water conditioning unit is warranted to the original end-user, when installed in accordance with Culligan International Company specifications, against defects in material and workmanship from the date of original installation, as follows:

For a period of ONE YEAR { **The entire reverse osmosis conditioning unit, including the reverse osmosis modules, but excluding the expendable filter cartridges used in this unit.**

If a part described above becomes defective, within the specified period, you should notify your independently operated Culligan dealer and arrange a time during normal business hours for the dealer to inspect the reverse osmosis unit on your premises. Any part found defective within the terms of this warranty will be repaired or replaced by the dealer. You pay only freight from our factory and local dealer charges.

Of course, damage caused by accident, fire, flood, freezing, Act of God, misuse, misapplication, neglect, alteration, installation or operation contrary to our printed instructions, or by the use of accessories or components which do not meet Culligan specifications, is not covered by this warranty.

Our product performance specifications are furnished with each water conditioning unit. TO THE EXTENT PERMITTED BY LAW, CULLIGAN DISCLAIMS ALL IMPLIED WARRANTIES INCLUDING, WITHOUT LIMITATION, WARRANTIES OF MERCHANTABILITY AND FITNESS FOR PARTICULAR PURPOSE; TO THE EXTENT REQUIRED BY LAW, ANY SUCH IMPLIED WARRANTIES ARE LIMITED IN DURATION TO THE ONE-YEAR PERIOD SPECIFIED ABOVE FOR THE PARTS DESCRIBED IN THIS LIMITED WARRANTY. As manufacturer, we do not know the characteristics of your water supply or the purpose for which you are purchasing a water conditioner. Please understand that the quality of water supplies may vary seasonally or over a period of time, and that your water usage rate may vary as well. Water characteristics can also change considerably if your water conditioner is moved to a new location. For these reasons, we assume no liability for the determination of the proper equipment necessary to meet your requirements, and we do not authorize others to assume such obligations for us. Further, we assume no liability and extend no warranties, express or implied, for the use of this product on a non-potable water source. OUR OBLIGATIONS UNDER THIS WARRANTY ARE LIMITED TO THE REPAIR OR REPLACEMENT OF THE FAILED PARTS OF THE WATER CONDITIONER, AND WE ASSUME NO LIABILITY WHATSOEVER FOR DIRECT, INCIDENTAL, CONSEQUENTIAL, SPECIAL, GENERAL, OR OTHER DAMAGES, WHETHER FROM CORROSION OR OTHER CAUSES.

CONSUMERS:

Some states do not allow limitations on how long an implied warranty lasts, so the above limitation may not apply to you. Similarly, some states do not allow the exclusion of incidental or consequential damages, so the above limitation or exclusion may not apply to you. This warranty gives you specific legal rights, and you may also have other rights which vary from state to state. Consult your telephone directory for your local independently-operated Culligan dealer, or write Culligan International Company, for warranty and service information.

**CULLIGAN INTERNATIONAL COMPANY
One Culligan Parkway
Northbrook, Illinois 60062**

Culligan[®] WRITTEN SPECIFICATION

SERIES B AND SERIES B PLUS REVERSE OSMOSIS SYSTEMS	CUSTOMER:
	PROPOSAL DATE:

The equipment described is being offered by _____,
an independently operated franchisee of Culligan International Company

PURPOSE

The purpose of the reverse osmosis system will be to reduce the dissolved mineral content of the water. The system will be capable, upon initial startup, of reducing the dissolved mineral content of the water by at least 98% (99% typical), based on membrane industry design standards, as described more fully below. The performance of the reverse osmosis system will depend on the nature of the water being treated. The system will be Culligan[®] model _____ reverse osmosis system which is designed to produce _____ gallons per day under standard operating conditions.

PREFILTER

The equipment will include one ten-inch replaceable element type prefilter. The filter housing will be of polypropylene construction and will include an integral pressure relief valve. The filter element will be of polypropylene construction and rated at 5 microns nominal size removal to assure maximum protection of the modules.

PUMP

A pump and motor assembly will be provided to boost the incoming water to an operating pressure of 250 psig. A rotary vane positive displacement pump with brass body will be provided. It will be close-coupled to a (check one):

- 1/3 HP (Models B-1S, B-1L, B-2L, B-3L)
- 1/2 HP (Models B-4L)

Electrical motor operating at 115VAC/50-60 Hz/1pH.

MODULES

The unit will use reverse osmosis elements in a spiral-wound configuration. The elements will be the polyamide thin film composite membrane type and will be capable, upon initial start-up of producing water at a nominal flow rate of

- (Models B-1S and B-1S Plus) 125 gallons per day
- (Models BL and BL Plus) 275 gallons per day

based on Culligan equipment specifications. Performance is based on membrane standard conditions of feed water at 77°F (25°C) containing 1500 mg/l NaCl and an operating pressure of 225 psig (1150 kPa). The module assembly will consist of (check one).

One (Models B-1S and B-1S Plus) Two (Models B-2L and B-2L Plus) Four (Models B-4L and B-4L Plus)
One (Models B-1L and B-1L Plus) Three (Models B-3L and B-3L Plus)

single element housing(s). Each element housing will be constructed of PVC and glass filled Noryl for corrosion resistance. Modules will be connected in an arrangement so to deliver the design capacity with minimal waste flow requirements.

CONTROL

The equipment will include all mechanical, hydraulic and electrical controls for a complete, self contained unit. A normally-closed solenoid valve will be mounted on the inlet to shut off the water supply when the unit is not operating. Operating pressure will be controlled by a needle-type high pressure control valve mounted on the waste line of the membranes. The valve will be equipped with a T-handle adjustment for setting the operating pressure. A fixed flow restrictor will be installed on the waste side of the module assembly to maintain the proper recovery ratio of product-to-feed water flow. A pressure gauge will be included. The gauge will be a liquid filled gauge to indicate the operating pressure of the unit. Operation of the unit will be controlled by an on-off switch located on the front side of the unit.

- (Series B Plus Systems) Connections will be provided to allow easy installation of an optional level control/pressurized storage kit, which will shut down the system and prevent overflow/overpressurization of an optional product water atmospheric/pressurized storage tank.

Connections will be provided to allow simplified wiring of an external signal switch, which will shut down the inlet solenoid and pressure pump during the regeneration cycle of pretreatment equipment to prevent untreated water from entering the reverse osmosis system. The system will start automatically when the pretreatment equipment has finished regeneration.

A pressure sensing switch will be installed after the inlet solenoid to protect the pressure pump from cavitation by shutting down the pump should pressure fall below 8 psig.

An indicating light mounted in the control enclosure will display low feed pressure when the condition exists.

ENCLOSURE

All the components, except the prefilter, will be mounted on a 10-gauge steel frame suitable for wall mounting. An optional 14-gauge steel wall bracket is available to simplify installation.

CONNECTIONS

The system will be designed with a 3/8-inch tube connection to the inlet of the prefilter and 3/8-inch tube connections from the prefilter to the feed connection on the unit. The product water connection will be 3/8-inch tube. The concentrate water connection will be 1/8".

An eight-foot cord with a 3-prong connector will be provided for connection to an electrical power source.

INSTRUCTIONS

A complete set of instructions covering the installation, operation, and maintenance of the equipment will be provided in booklet form.

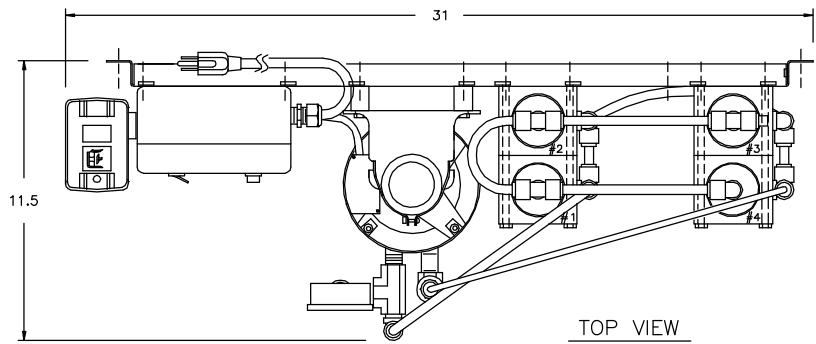

TOP VIEW

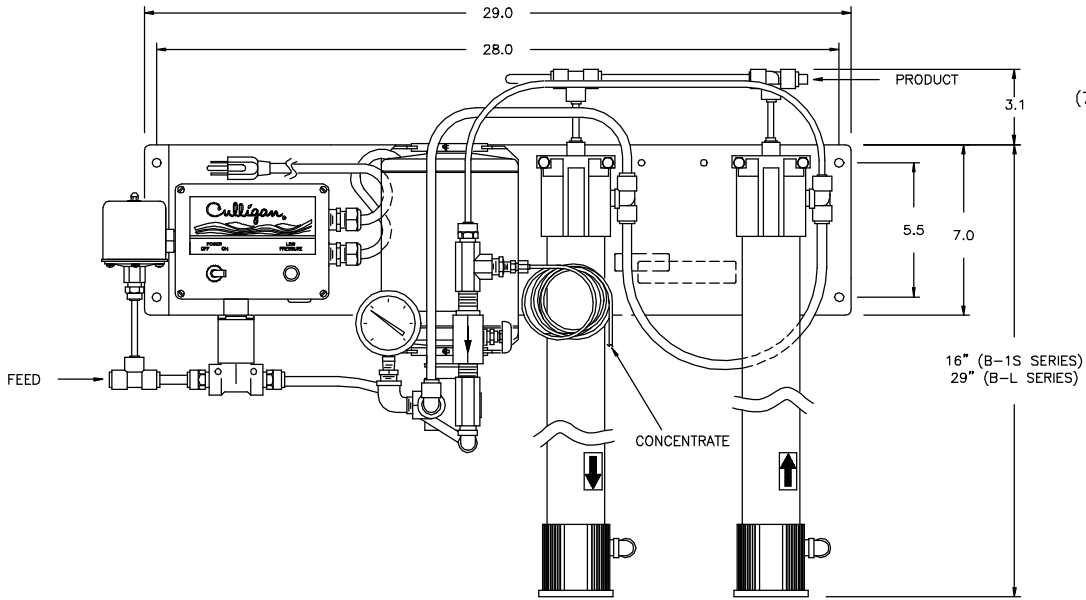

B-4L PLUS SHOWN (FRONT VIEW)

NOTES:

- (1) ALL DIMENSIONS ARE GIVEN IN INCHES AND ARE APPROXIMATE.
- (2) A PREFILTER IS PROVIDED AS PART OF THE UNIT. THE INSTALLER MAY WALL MOUNT THE 4 1/2" DIAMETER X 12" LONG PREFILTER TO ANY CONVENIENT LOCATION. THE PREFILTER HAS 3/8" TUBE CONNECTIONS. PLASTIC 3/8" TUBING CONNECTS THE OUTLET OF THE PREFILTER TO THE FEED WATER INLET OF THE SERIES B UNIT.
- (3) THE PRODUCT WATER AND THE INLET WATER CONNECTION IS 3/8" TUBING.
- (4) THE CONCENTRATE WATER CONNECTION IS 1/8" TUBING (EXCEPT B-4L IS 3/16")
- (5) AN OPTIONAL BRACKET FOR WALL MOUNTING ON 16", 18" OR 20" CENTERS IS AVAILABLE. THE WALL MUST BE CAPABLE OF SUPPORTING AT LEAST 60 POUNDS.
- (6) PROVIDE A DRAIN CAPABLE OF HANDLING AT LEAST 2.1 GALLONS PER MINUTE. DO NOT MAKE A DIRECT CONNECTION TO THE DRAIN. PROVIDE AN AIR GAP OF AT LEAST FOUR TIMES THE DIAMETER OF THE DRAIN PIPE TO CONFORM TO SANITATION CODES AND TO PERMIT THE OBSERVATION OF THE DRAIN FLOW. DO NOT INSTALL A VALVE IN DRAIN LINE.
- (7) THE POWER CORD IS 8 FEET.

				Culligan®			
				NORTHBROOK, ILLINOIS			
		SCALE 00.00		DETAILED BY KMR		CHECKED BY	
		REF. NO.		DATE 3/4/99		DATE	
LET		CHANGE		BY APP		DATE	
PRINT & BILL OF MATERIALS ARE NOT TO BE USED WITHOUT THE WRITTEN CONSENT OF CULLIGAN USA DO NOT SCALE FROM DRAWING				NAME SERIES B REVERSE OSMOSIS SYSTEMS TECHNICAL DATA SHEET		PART NO. RO_B SHEET 1 OF 1	